

Loop-the-Loop as a Real Tribomechanical System Applicable in Engineering Education

J. Milojkovic^{a,*}, V. Kocovic^a, A. Kosarac^b, K. Simunovic^c

^aUniversity of Kragujevac, Faculty of Engineering, Sestre Janjić 6, Kragujevac, Serbia,

^bUniversity of East Sarajevo, Faculty of Mechanical Engineering, Vuka Karadžića 3, East Sarajevo, Republic of Srpska, Bosnia and Herzegovina,

^cUniversity of Slavonski Brod, Mechanical Engineering Faculty in Slavonski Brod, Trg Ivane Brlic Mazuranic 2, Slavonski Brod, Croatia.

Keywords:

Energy losses
Loop-the-loop
Friction
Engineering education

ABSTRACT

Using a "loop-the-loop" system, the authors developed a double-track apparatus and based their experimental research on theoretical foundations related to the motion on an inclined plane laid by Leonhard Euler. The method enabled the quantification of very small "energy losses". The paper presents the results of experimental research and the analysis of the changes in friction force and other causes of energy dissipation. In engineering education, the method contributes to a deep understanding of the concept of energy transformation – the appearance of "energy losses" in real tribomechanical systems.

* Corresponding author:

Jasmina Milojkovic 
E-mail: jasmina.miljojkovic@fink.rs

Received: 5 September 2021

Revised: 10 October 2021

Accepted: 16 November 2021

© 2021 Published by Faculty of Engineering

1. INTRODUCTION

Enhancing the learning process and helping students understand the various aspects of friction phenomena and energy conservation law can be challenging [1-6]. In engineering education, this issue seems to be of particular importance, as various industry branches rely significantly on the application of friction.

The knowledge of the effects of friction on the interaction between the surfaces of various materials in different operating conditions is of fundamental importance in many areas of

engineering. Demonstration of the effects of friction in laboratory conditions that enables students to understand the theoretical bases, acquiring the relevant knowledge necessary for future engineering practice at the same time, sometimes requires the development of special devices. For example, considering the growing number of devices operating under high vacuum, Tadic et al. [7] constructed a device to measure the friction force acting on the pneumatic cylinder sealing rings under a high vacuum. In a similar context related to the implementation and the effects of friction in real dynamic conditions, Mihajlovic et al. [8] developed a

vibroplatform model to study the friction between the screen and sand granules.

Several different tribometers, such as those for studying the static coefficient of rolling friction at high contact temperatures and various contact pressure [9] or for determining the static coefficient of friction at high temperatures [10], were designed based on a principle of an inclined plane. Vukelic et al. [11] recently presented a device and proposed a method based on the equation of motion of a rigid body along an inclined plane that allows the quantification of friction parameters of real industrial products (sliding guides, etc.).

An inclined plane concept has been used for a long time to demonstrate the effects of sliding and rolling friction and energy dissipation. Rabinowicz [12] measured the energy one body needs to transmit to another to initiate its movement down an inclined plane. Mungan [13] determined a universal equation for the ratio of the effective frictional force to the normal force. Some authors [14] study the static friction and inclination angle limits needed to achieve rolling without slipping. Cross [15] found that the body's compression and expansion in the contact region cause energy dissipation on an inclined plane, directly proportional to the rolling friction coefficient.

The so-called "loop-the-loop" experiments, often associated with roller coasters [16] to make classes more interesting and related to the real world, have been used in physics and introductory mechanics classes for a long time for the demonstration of mechanical energy conservation law [17]. "Loop-the-loop" systems consist of an inclined track that forms a vertical loop before becoming a ramp for the projectile motion. However, a broadly used equation defining the minimum height from which the body should start its motion down the inclined part of a track before entering the vertical loop as 5/2 of the loop's radius does not take the friction into account. In a real "loop-the-loop" system, where the rolling of a solid sphere is combined with occasional sliding, relying on this equation leads to a discrepancy between the expected and experimental results [18]. As Tea Jr points out [19], in real systems, the ratio between the initial height and the loop's radius has to be at least 2.7 to ensure that the ball completes the loop.

When used in engineering education, "loop-the-loop" setups should be treated as real tribomechanical systems. In that case, the analysis of the causes of energy dissipation, both from the aspect of the construction imperfections and the aspect of friction effects, becomes a beneficial teaching/learning method.

Using a "loop-the-loop" system, the authors of this paper developed a double-track apparatus and based their experimental research on theoretical foundations related to the motion on an inclined plane laid by Leonhard Euler [20,21]. The method enabled the quantification of very small "energy losses" [22]. In addition to the results of experimental research, here we present the analysis of the changes in friction force along the track and the analysis of other causes of energy dissipation.

2. THEORETICAL ANALYSIS

A steel ball rolls along the path of the length s , from point A to point D (Fig. 1).

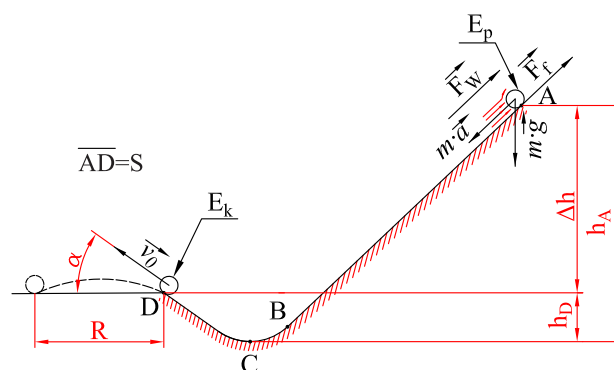

Fig. 1. Schematic representation of the method.

At point "A", the total energy of the ball is equal to its potential energy E_p . After the initiation of motion, the rolling ball has kinetic energy E_k . At point D, the ball leaves the track at angle α , starting the oblique projectile motion. After measuring the range R of the projectile motion, we can calculate the "energy losses", starting with the following equation:

$$\Delta E = E_p - E_k = m \cdot g \cdot \Delta h - \frac{1}{2}mv^2. \quad (1)$$

where m is the mass of the ball, g is the gravitational acceleration, Δh is the difference between heights h_A and h_D , and v is the velocity of the ball. So, the "energy losses" are equal to the

difference between the energy of the ball at point A (potential energy) and the energy of the ball at point D (kinetic energy).

At point D, the ball becomes a projectile, so using the known equation for the projectile velocity:

$$v^2 = \frac{R \cdot g}{\sin 2\alpha} \quad (2)$$

and substituting v^2 into equation (3), we can calculate the total "energy losses" as follows:

$$\Delta E = m \cdot g \cdot \Delta h - \frac{R \cdot g \cdot m}{2 \cdot \sin 2\alpha} \quad (3)$$

In this case, the air resistance force can be neglected, considering the small frontal area of the ball (radius of the ball equals 4 mm) and its small velocity. Therefore, the "energy losses" are considered to be caused by friction. The work W_f done by the friction force is the function of friction force F_f along the path s :

$$dW_f = F_{f(s)} \cdot ds \quad (4)$$

and, respectively:

$$W_f = \int_0^s F_{f(s)} \cdot ds \quad (5)$$

Considering that the "energy losses" are equal to the work done by friction, we can write as follows:

$$\Delta E = W_f \equiv \bar{F}_{f(s)} \cdot s \quad (6)$$

So, the mean value of friction force $\bar{F}_{f(s)}$ along the path s equals:

$$\bar{F}_{f(s)} = \frac{\Delta E}{s} \quad (7)$$

3. EXPERIMENTAL RESEARCH

A double-track apparatus based on a "loop-the-loop" system (Fig. 2a) is as presented in [22]. The tracks are made of aluminium U profiles (width: 12 mm, height: 8 mm). The length s_1 of Track 1 is 3,02 m, while the length s_2 of Track 2 equals 1,195 m. The shorter track is concave, while the longer track forms a double vertical loop (Fig. 2b) before becoming a ramp for a projectile motion. The tracks have identical initial and ending heights h_A and h_D , and they both form an identical angle α with the horizontal.

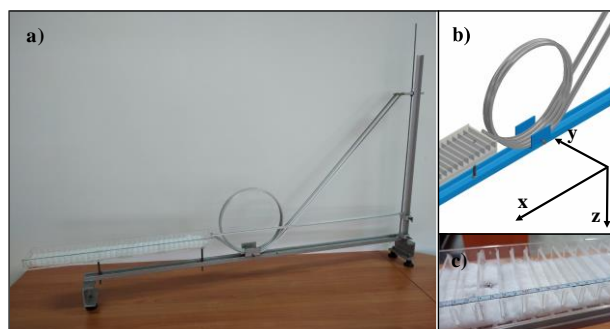

Fig. 2. a) The apparatus; b) 3D model – detail.

The calculations are based on the measurement of the ball's range and the Eqs. (1), (2), (3), and (7). After leaving the track at point "D", the ball moves according to the law of oblique projectile motion and lands on a horizontal part of the apparatus made of equal sections with a meter on the upper side (Fig. 2 c). The bottom of the sections is cotton-lined to prevent the bouncing of the ball when it lands. The inclination angle was set to 39°, while Δh was 0.555 m. The mass of the ball equals 2.10445 g, so the potential energy E_p equals 0.01146 J.

The mean results of 30 measurements [22] for each track are presented in Table 1 and Table 2.

Table 1. Results for Track 1

s_1 (m)	\bar{R}_1 (m)	$\Delta \bar{E}_1$ (J)	\bar{E}_{k_1} (J)	\bar{F}_{f_1} (N)
3.02	0.462	0.00658	0.00488	0.00218

Table 2. Results for Track 2

s_2 (m)	\bar{R}_2 (m)	$\Delta \bar{E}_2$ (J)	\bar{E}_{k_2} (J)	\bar{F}_{f_2} (N)
1.195	0.534	0.00582	0.00564	0.00487

4. DISCUSSION

A comparative view of calculated values of kinetic energy and "energy losses" on both tracks, as well as the value of potential energy, are given in Fig. 3. Quantified levels of energies (kinetic energy and "energy losses") range from approximately 0,004 J to 0,007 J [22].

Data provided in Tab. 1, Tab. 2 and Fig. 3 indicate that "energy losses" are smaller on Track 2 than on Track 1. However, Eq. (3) shows that when the ball ranges are identical for both tracks (as was the case in several measurements), "energy losses" are identical as well, while the average friction force has

a higher value on the shorter track (Eq. 7). That indicates the combined effect of the friction force and the length of the path on "energy losses".

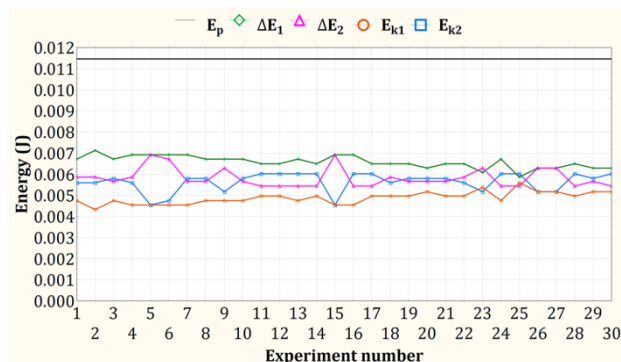

Fig. 3. Energy levels comparison [22].

By analysing the ball's motion along the shorter track, using Eq. (5), it is possible to predict and graphically describe how the friction force changes while the ball travels along its path (Fig. 4). The area under the curve is equal to the work done by the friction force.

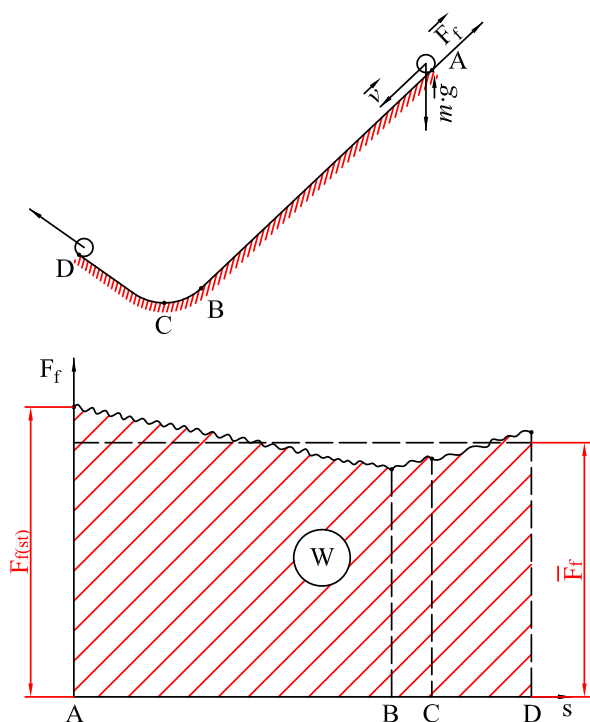

Fig. 4. Friction force along the shorter track.

The friction force will have the highest value at the beginning of the track, considering the static friction that must be overcome in order to initiate the motion down the track. As the ball accelerates down the inclined part of the track (from point A to point B), the value of friction force decreases. On the arched part of

the track, the ball's velocity will decrease, while the value of the friction force will increase, keeping the rising trend until the ball leaves the track (at point D). The mean value of friction force on the shorter track, calculated based on Eq. (7), equals 0.00218 N.

A more detailed analysis of the experimental results (especially the variations of the projectile range) should take into account the geometric imperfections of the track, as well as the condition of its surface. The shape of the curve in Fig. 5 reflects the existence of micro-impacts during the ball's movement along the track. Furthermore, the ball of 8 mm diameter moves inside the 10 mm wide track (an internal measure of the U-profile cross-section). The clearance of 1 mm between the ball and the interior sides of the track causes micro-impacts. It means that there is a certain motion of the ball along the xy -plane as well (Fig. 2b), which is perpendicular to the plane of the drawing given in Fig. 4. By taking into account the geometric imperfections of the track and the arc shape of the track's cross-section, the assumed deviation of the actual trajectory of the centre of mass from the ideal trajectory is given in Fig. 5.

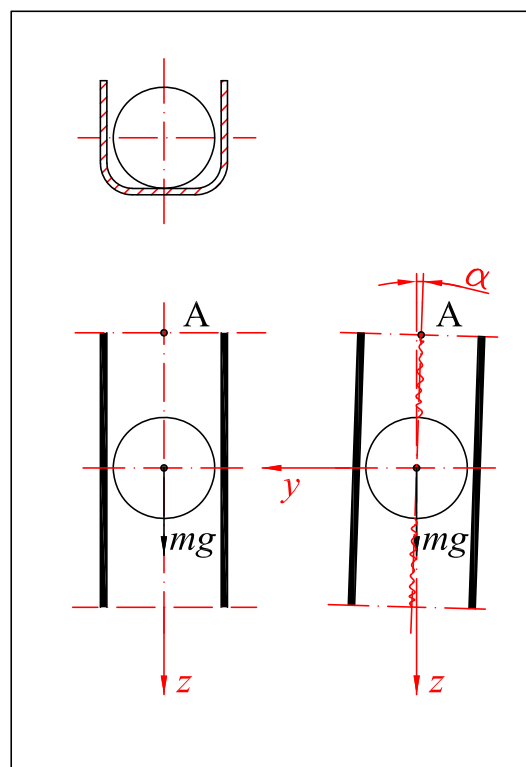

Fig. 5. Deviation of the actual trajectory of the centre of mass from the ideal trajectory.

Due to the imperfections of the track, one can expect the existence of certain lateral and vertical deviations of the actual shape of the trajectory from its ideal shape. Furthermore, the ball will actually travel the path that is to some extent longer than the path equal to the length of the track, i.e. the actual travelled path will be longer than the path the ball would travel in ideal conditions, without micro-impacts.

The analysis of the ball's motion along the longer track indicates more dynamic changes in the values of friction force. Those changes correspond to the changes in the shape of the track, which forms a double circle at a certain point before straightening again and allowing the ball to continue to move linearly towards point D (Fig. 6).

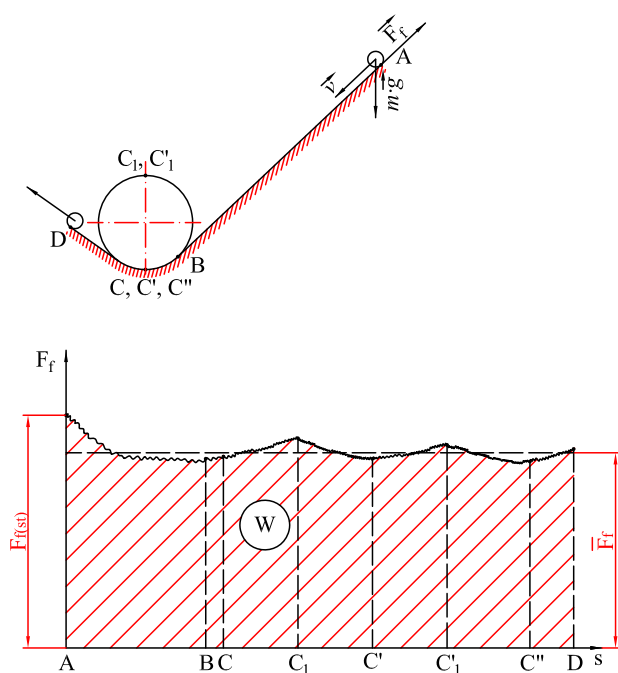

Fig. 6. Friction force along the longer track.

As in the first case, the friction force will decrease while the ball rolls from point A to point B and increase as the ball decelerates along the first circle (from the lowest point C to the highest point C_1). It will decrease again as the ball descends (re-accelerates) down the circle. The ball then repeats the same path along the second loop (B-C'- C_1' -C"). After that, the friction force will increase while the ball moves linearly towards point D before leaving the track. The mean value of friction force on the longer track, calculated based on Eq. (7), equals 0.00487 N.

5. CONCLUSION

The proposed method based on Euler's research enables the quantification of very small "losses" of mechanical energy of the order of 10^{-3} J in real tribomechanical systems, where the effects of friction and factors causing the deviation from the ideal functioning of the system must be taken into account. In the presented case, those factors include the geometric imperfections of the track and the condition of its surface, the existence of micro-impacts between the ball and the track's side walls, the oscillatory motion of the ball on the plane perpendicular to the plane of the ball's theoretical trajectory (Figs. 4, 5 and 6). Those factors cause the deviation of the actual shape of the ball's path in relation to its ideal path, so it can be assumed that the path the ball actually travels along the track is to some extent longer than the path that the ball would travel in ideal conditions.

In engineering education, the proposed method helps students to understand the essence of the concept of energy transformation – the appearance of "energy losses" in real tribomechanical systems and enables the initiation of a discussion on various aspects of the friction phenomenon, as well as the analysis of differences between the real and ideal systems.

Further research should include the use of sensors and/or a digital camera for measuring the time and the distance travelled by the ball. By relying on Euler's approach [11], the friction coefficient could be determined on specific sections or even specific points of the track.

REFERENCES

- [1] U. Besson, L. Borghi, A. De Ambrosis, P. Mascheretti, *How to teach friction: Experiments and models*, American Journal of Physics, vol. 75, iss. 12, pp. 1106-1113, 2007, doi: [10.1119/1.2779881](https://doi.org/10.1119/1.2779881)
- [2] P. Logman, W. Kaper, T. Ellermeijer, *Evaluation of the learning process of students reinventing the general law of energy conservation*, Eurasia Journal of Mathematics Science and Technology Education, vol. 11, iss. 3, pp. 479-504, 2015, doi: [10.12973/eurasia.2015.1323a](https://doi.org/10.12973/eurasia.2015.1323a)
- [3] J. Solbes, J. Guisasola, F. Tarín, *Teaching energy conservation as a unifying principle in physics*. Journal of Science Education and Technology, vol. 18, iss. 3, 265-274, 2009, doi: [10.1007/s10956-009-9149-3](https://doi.org/10.1007/s10956-009-9149-3)

- [4] A. De Ambrosis, M. Malgieri, P. Mascheretti, P. Onorato, *Investigating the role of sliding friction in rolling motion: a teaching sequence based on experiments and simulations*, European Journal of Physics, vol. 36, no. 3, pp. 1-21, 2015, doi: [10.1088/0143-0807/36/3/035020](https://doi.org/10.1088/0143-0807/36/3/035020)
- [5] P.S. Wulandari, C. Cari, N.S. Aminah, D.A. Nugraha, *Pre-service teachers' conceptual understanding of rolling friction coefficient*, AIP Conference Proceedings, vol. 2014, iss. 1, pp. 1-9, 2018, doi: [10.1063/1.5054464](https://doi.org/10.1063/1.5054464)
- [6] L. Minkin, D. Sikes, D. *Coefficient of rolling friction-Lab experiment*, American Journal of Physics, vol. 86, iss. 1, pp. 77-78, 2018, doi: [10.1119/1.5011957](https://doi.org/10.1119/1.5011957)
- [7] B. Tadic, M. Zivkovic, G. Simunovic, V. Kocovic, T. Saric, D. Vukelic, *The Influence of Vacuum Level on the Friction Force Acting on the Pneumatic Cylinder Sealing Ring*, Tehnicki vjesnik – Technical Gazette, vol. 26, no. 4, pp. 970-976, 2019, doi: [10.17559/TV-20180227172122](https://doi.org/10.17559/TV-20180227172122)
- [8] G. Mihajlović, M. Gašić, M. Savković, S. Mitrović, B. Tadić, *Vibroplatform modeling with allowance for tribological aspects*, Journal of Friction and Wear, vol. 38, iss. 3, pp. 184-189, 2017, doi: [10.3103/S1068366617030102](https://doi.org/10.3103/S1068366617030102)
- [9] B. Tadić, V. Kočović, M. Matejić, L. Brzaković, M. Mijatović, *Static coefficient of rolling friction at high contact temperatures and various contact pressure*, Tribology in Industry, vol. 38, no. 1, 83-89, 2016.
- [10] M. Lukovic, J. Miljojkovic, B. Tadic, *An inclined plane based instrument for determining the static coefficient of friction at high temperatures*, Romanian Journal of Physics, vol. 66, no. 9-10, pp. 909, 2021.
- [11] D. Vukelic, P. Todorovic, K. Simunovic, J. Miljojkovic, G. Simunovic, I. Budak, B. Tadic, *A novel method for determination of kinetic friction coefficient using inclined plane*, Tehnicki vjesnik – Technical Gazette, vol. 28, no. 2, 447-455, 2021, doi: [10.17559/tv-20201101051835](https://doi.org/10.17559/tv-20201101051835)
- [12] E. Rabinowicz, *The nature of the static and kinetic coefficients of friction*, Journal of applied physics, vol. 22, iss. 11, pp. 1373-1379, 1951, doi: [10.1063/1.1699869](https://doi.org/10.1063/1.1699869)
- [13] C.E. Mungan, *Rolling friction on a wheeled laboratory cart*, Physics Education, vol. 47, no. 3, pp. 288-292, 2012, doi: [10.1088/0031-9120/47/3/288](https://doi.org/10.1088/0031-9120/47/3/288)
- [14] J. Bartoš, J. Musilová, *Small surprises in 'rolling-physics' experiments*, European journal of physics, vol. 25, no. 5, pp. 675-687, 2004, doi: [10.1088/0143-0807/25/5/010](https://doi.org/10.1088/0143-0807/25/5/010)
- [15] R. Cross, *Rolling to a stop down an inclined plane*, European Journal of Physics, vol. 36, no. 6, pp. 065047, 2015, doi: [10.1088/0143-0807/36/6/065047](https://doi.org/10.1088/0143-0807/36/6/065047)
- [16] A.M. Pendrill, *Student Investigations of Forces in a Roller Coaster Loop*, European Journal of Physics, vol. 34, no. 6, pp. 1379-1389, 2013, doi: [10.1088/0143-0807/34/6/1379](https://doi.org/10.1088/0143-0807/34/6/1379)
- [17] S.J. Briggs, *Hot Wheels Physics*, The Physics Teacher, vol. 8, iss. 5, pp. 257-259, 1970, doi: [10.1119/1.2351481](https://doi.org/10.1119/1.2351481)
- [18] N. Suwonjandee, B. Asavapibhop, *Loop-the-loop: bringing theory into practice*, Physics Education, vol. 47, no. 6, pp. 751-754, 2012, doi: [10.1088/0031-9120/47/6/751](https://doi.org/10.1088/0031-9120/47/6/751)
- [19] P.L. Tea Jr, *Trouble on the loop-the-loop*, American Journal of Physics, vol. 55, iss. 9, pp. 826-829, 1987, doi: [10.1119/1.14997](https://doi.org/10.1119/1.14997)
- [20] V.P. Zhuravlev, *On the history of the dry friction law*, Mechanics of solids, vol. 48, iss. 4, 364-369, 2013, doi: [10.3103/S002565441304002X](https://doi.org/10.3103/S002565441304002X)
- [21] L. Euler, *Sur le frottement des corps solides*. Memoires de l'academie des sciences de Berlin, pp. 122-132, 1750, available at: <http://eulerarchive.maa.org/>, accessed: 15.10.2021.
- [22] J. Miljojkovic, S. Kostic, V. Kocovic, B. Tadic, *Quantification of energy losses in real mechanical systems*, in 26th Conference Trendovi razvoja: Inovacije u modernom obrazovanju, 16-19 February, 2020, Kopaonik, Serbia, Faculty of technical Sciences Novi Sad, pp. 230-233.