

Analysis of Composite Worm Gear Ring Wear and Lubrication Conditions Due to Torque Testing

Bima Cahya Maula Dana^a , Syamsul Hadi^{a,*} , Rizal Wahyu Permana^a , Hangga Wicaksono^a ,
Aminnudin^b , Mohammad Sukri Mustafa^c 

^aMechanical Engineering Dept., State Polytechnic of Malang, Malang 65141, Indonesia,

^bMechanical and Industry Engineering Dept., State University of Malang, Malang 65145, Indonesia,

^cMechanical Engineering Dept., Universiti Tun Hussein Onn, 86400 Parit Raja, Johor, Malaysia.

Keywords:

Carbon fiber
Lubrication conditions
Onyx
Wear
Worm gear ring composite

* Corresponding author:

Syamsul Hadi
E-mail: syamsul.hadi@polinema.ac.id

Received: 28 March 2024

Revised: 6 June 2024

Accepted: 15 November 2024

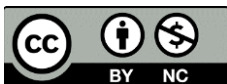

ABSTRACT

The unknown thickness of wear between the 3D-printed worm gear ring composite and the steel worm in the reduction gear of the torque testing machine with various lubrication conditions is a problem. Research methods include removing a new brass worm gear ring, 3D scanning, modifying cloud data, creating working drawings, 3D printing composites (worm gear rings) of Onyx and Onyx+10%CF materials, installing the composite on holder steel wheels, placing the steel worm axle into the reduction gear, torque testing with three lubrication conditions dry, SAE 10W-30 Oil, and Castrol Lithium Grease (CLG) with 180 steel specimens, and preparing Scanning Electron Microscope (SEM) photograph specimens. The results of the research are wear between steel tooth with Onyx composite from largest to smallest value in oil worth 0.1300 mm, dry worth 0.0943 mm, and CLG worth 0.0650 mm; wear between the Onyx+10%CF composite on the worm gear ring from the largest to the smallest value for oil worth 0.0970 mm, dry worth 0.0630 mm, and CLG worth 0.0030 mm; and there is an interaction between the composite and the oil which changes the color of the used oil to become darker.

© 2025 Published by Faculty of Engineering

1. INTRODUCTION

The problem that is often encountered with reduction gears is that if there is damage to the worm gear ring which is broken or worn, then purchasing a set of reduction gears is relatively expensive, so making spare parts via 3D printing is possible. If a manufacturer no longer supplies spare parts for a machine it sells, the solution is to manufacture it via 3D printing as an

alternative. One step to overcome this problem is to use alternative composite materials from onyx or onyx combined with carbon fiber (CF) in 3D printing composite worm gear rings to increase their strength.

A pair of worm and worm gears have a certain rotational speed ratio, if the ratio value is small, then the reducing value is high [1]. Worm gears are often used in machine tools, transportation

vehicles, especially for power transmission and in devices that regulate movement transmission speeds [2]. In the torque testing, the rotational speed is required to be slow enough to obtain data on the torsion angle and torque.

Reduction gear is used to change speed from a high to a low of which one example of the torque test machine available at the Department of Mechanical Engineering, State Polytechnic of Malang, Indonesia uses a first stage reduction gear ratio, 1:100 and a second stage ratio, 1:60 which contains a brass worm gear ring which is replaced with a 3D printed composite, if the supply of brass gear rings is not available.

A pair of steel worm and brass worm gears were used during the test series in particle wear observations [3]. In the research, wear measurements were carried out only on composite gears, and steel worms were assumed not to wear. Scientists have investigated the rules regarding the loading and deformation of the contact surfaces of worm gears in helical gears [4]. In the torque test, the level of wear was observed only on the composite worm gear ring in contact with the surface of the steel worm. The tooth life of a worm gear can be increased significantly, estimated to be around 56% in the condition of engagement of three pairs of teeth rather than engagement of double gears [5]. Wear between the steel worm gear and the teeth of the contacting composite worm gear ring with Castrol Lithium grease (CLG) experiences less wear than in contact with oil or dry media, which means the potential to have a longer service life for a single gear pair like engagement on double gears.

Wear can cause a reduction in the contact force between the teeth, so that the total power transmitted by the worm gear decreases [6]. Therefore, wear measurement research is important to carry out so that predictions of power reduction can be known.

The worm and worm gear during torque transmission cause friction, which requires constant lubrication of the appropriate quality to minimize wear. Wear between worm teeth and worm can be achieved at a minimum value if friction during torque transmission is used constant lubrication [7]. In the observation of wear between the worm gear ring of Onyx composite material with the addition of 3D printed CF and

paired with medium carbon steel worm, it shows a significant level of wear with an indication of increased turbidity of SAE 10W-30 lubricant.

By comparing the tribological properties of lubricants, it is stated that SAE 20W-40 and SAE 20W-50 lubricants have better performance than SAE 10W-30, which of the two thicker lubricants may contain more antioxidant additives [8]. The use of SAE 20W-40 and SAE 20W-50 lubricants states that these lubricants are better than SAE 10W-30 because antioxidant additives can form a surface layer to reduce contact, to reduce wear and friction between tooth contacts of the gear.

At the change of contact conditions after the tooth wear limit, the contact pressure is much lower, the gear life is practically the same, and the worm wheel tooth wear is slightly higher than the constant condition of the gear curvature radius [9]. Changes in gear curvature can result in different wear and service life.

Polymer composites have successfully replaced the tribological properties of polyamide 6,6 polymer composites through smart material design of CF-epoxy as nano scale reinforcement as a viable alternative material in components with strength close to metals [10]. Onyx composites with the addition of 10% Carbon Fiber (10%CF) can replace the function of the original brass worm gear ring.

The worm gear ring has an isolated pressure area in the oil flow from the worm wheel at the contact point, producing a stable oil film, which can help separate the friction surface or contact area of the worm and the worm gear ring, eliminating dry friction [11]. The formation of a lubricating film to avoid direct contact between the worm gear ring and the steel worm, while the latest observation formed a sealing film of SAE 10W-30 between the worm gear ring made of Onyx+CF10% and the worm from medium carbon steel.

Dynamically loaded specimens showed higher wear compared to static conditions in all experiments, with an even more significant impact on contact surfaces lubricated with SAE 10W-30 [12]. Mineral lubrication has a more significant impact than bio-based oil in the sense that the coefficient of friction of bio-based oil is smaller than that of mineral oil.

The determined values of tribological parameters, such as coefficient of friction, frictional power, and dynamic viscosity, provide a comprehensive tribological evaluation of the tested grease. The determination of these tribological parameters provides information on lubrication performance in various operating temperatures [13]. The coefficient of friction of the rubbing materials and the type of lubrication has a significant impact, including the resulting friction force. An example application is shown in the coupling between the friction of an onyx worm gear ring and a worm of medium carbon steel under various lubrication conditions (dry, oil, and CLG).

Normal loads greatly influence the wear of the composite. Damage to composite fibers has the most significant impact on wear mechanisms. Various aspects of wear behavior were observed with SEM showing numerous microcracks and wear debris of the fiber composite. Fiber composites are easy to make with a wide range of fiber lengths, and the tribological properties are better for a 15 mm fiber length under a 20 N load of 1200 mesh with natural fibers than for other fibers [14]. Long fibers with a smooth contact surface with a sliding load of 20 N can cause cracking of the composite, while micro-sized fibers on a relatively smooth surface with a sliding load of 140 N do not cause cracking.

Composites are widely used for structural applications due to their higher strength-to-load ratio, excellent stiffness, and better corrosion and wear resistance than other polymeric materials [15]. This can improve the manufacturing technology of key structural parts. 3D printing of polymer composites with improved mechanical properties solves previous limitations through the addition of particles or fibers or nano-sized materials into thermoplastic polymers for the manufacture of polymer matrix composites.

The difference in fiber type has a significant effect on the service life of a gear pair. The predicted service life between CF-reinforced gears, and pinions is about 9 times greater than that of glass fiber-reinforced gears and pinions over all ranges of contact pair modifications involving metallic materials [16]. The fiber-reinforced material of the pinion greatly influences the value of service life resistance of the gear under various conditions of contact pair modification associated with metallic materials.

Manufacturing of 3D-printed components reinforced with continuous CF materials in composite prototype products with the advantage of complex shape products from fused deposition modeling (FDM) results of a composite component design. It is promising to manufacture continuous fiber-reinforced composites from 3D printing after improvement [17,18]. The combination of using continuous fibers using the FDM method promises to produce complex products that are better and quite efficient, especially for worm gear ring products made of CF-reinforced Onyx as an alternative to worm gear rings previously made of brass. By reducing the use of metal materials and replacing them with polymer composites, the level of wear and friction can be reduced, and the service life can be longer. However, it is worth realizing that polymer composite materials have the potential to burn if worked at higher temperatures.

2. MATERIAL AND METHOD

The type of research used is experimental research. This research aims to obtain the level of composite worm gear ring wear and lubrications due to intermittent torque test machine loads, where in this research, the intermittent duration is removed so that it can be assumed to be a continuous load. The flow diagram of the research is shown in Figure 1.

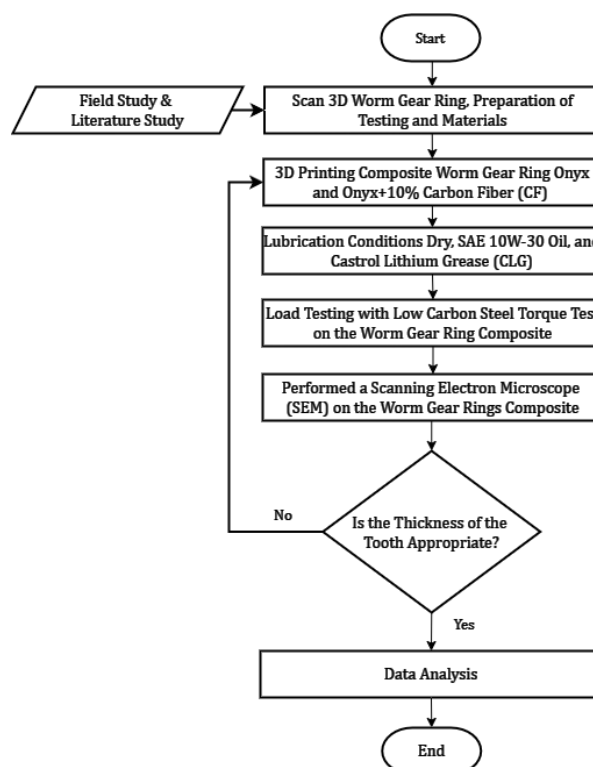

Fig. 1. Research flow diagram.

2.1 Filament Onyx and CF

The material composition of Onyx (Markforged) and CF obtained from the results of Energy Dispersive Spectroscopy (EDS) which refers to Scanning Electron Microscope (SEM) photographs resulting in several elemental peaks is shown in Table 1. Obtained mainly in the form of carbon (C) with an increase for onyx material alone, the percentage mass obtained was 74.63%, while the Onyx material plus 10%CF obtained an increase in carbon mass of 76.01%, while the element O as an accompaniment was the remainder of the total 100% of the material, impurities were found in the form of Fe, Ag, and I.

Table 1. EDS result of Onyx and Onyx+10%CF.

SEM and EDS of Onyx Material				
Element	Atom Number	Netto	Mass (%)	Atom (%)
C	6	979	74.63	79.69
O	8	159	25.33	20.31
Fe	26	0	0.03	0.01
Ag	47	0	0.00	0.00
Amount (%)			100.00	100.00
SEM and EDS Material Onyx+10%CF				
Element	Atom Number	Netto	Mass (%)	Atom (%)
C	6	2650	76.01	83.31
O	8	282	18.89	15.54
Fe	26	144	4.72	1.11
I	53	6	0.39	0.04
Amount (%)			100.00	100.00

SEM photographs can be followed by determining the composition of an element in a photography area in the form of EDS points shown in Figure 2 and Figure 3, which are displayed sequentially as SEM photos followed by their EDS graphs.

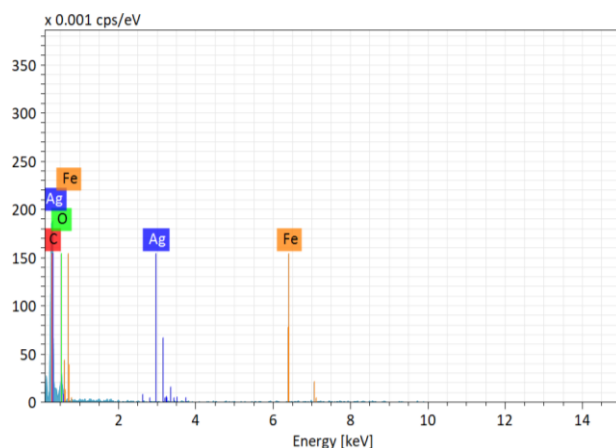
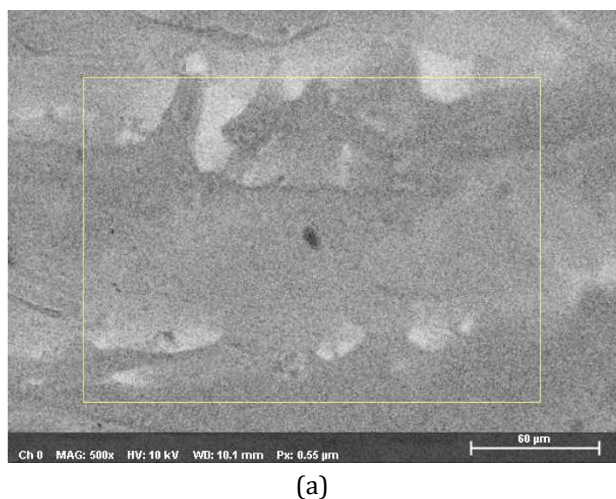

Fig. 2. (a) SEM and (b) EDS of Onyx material.

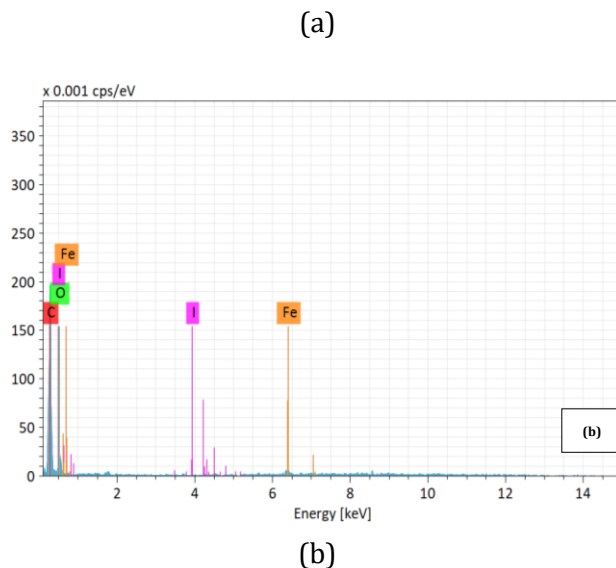
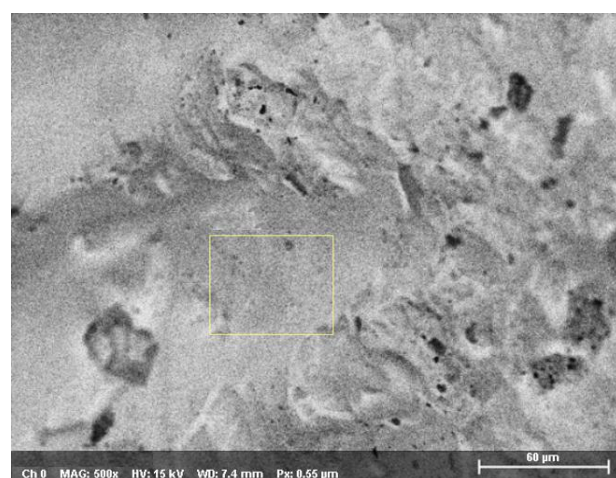

Fig. 3. (a) SEM and (b) EDS material Onyx+10%CF.

Composite materials in the form of Markforged 3D printing filament as an alternative according to the American Standard for Testing and Materials (ASTM) are shown in Table 2.

Table 2. Composite properties that refer to standards.

Mechanical Properties	ASTM Test Standards		
	Onyx Base Composite (D638)	Continuous CF (D3039)	Onyx+10%CF Composite (D638)
Tensile Strength (MPa)	40	800	93
Tensile Modulus (GPa)	2.4	60	3.1
Tensile Stress at Break (MPa)	37	-	87
Density (g/cm ³)	1.2	1.4	1.49*

* It is suspected that there is a foreign material.

Table 2 shows the tensile strength for Onyx+10%CF material worth 93 MPa obtained by tensile testing for several 3 specimens referring to the ASTM D638 standard is shown in Figure 4. Complete information regarding tensile modulus, tensile stress at break, and density is also included.

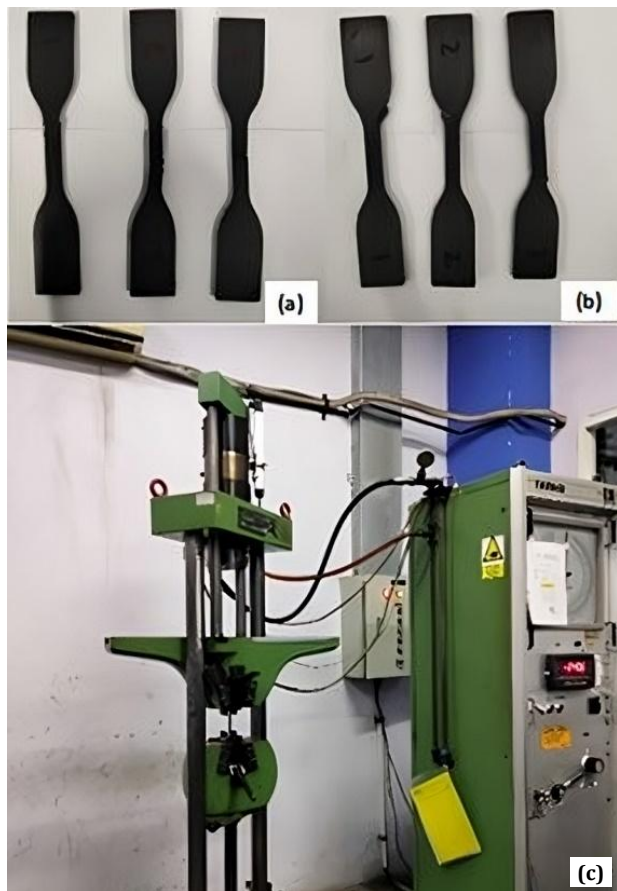

Fig. 4. Tensile testing: (a) Onyx specimens, (b) Onyx+10%CF specimens, and (c) Universal testing machine.

2.2 Worm gear ring printing

The object used in the research is the worm gear ring in the reduction gear which is made from the following composite material:

1) Brass worm gear ring

The brass worm gear ring was scanned by the Faro Quantum device, modified, and printed with a 3D printer using Onyx material is shown in Figure 5. The black colour on the brass surface is painted to prevent the Faro Quantum device from being able to capture cloud data.



Fig. 5. Brass worm gear rings.

2) Scan 3D

3D scanning is used to obtain a point cloud that is scanned in standard triangle language (STL) format. The results of the 3D scan using the Faro Quantum device are shown in Figure 6.

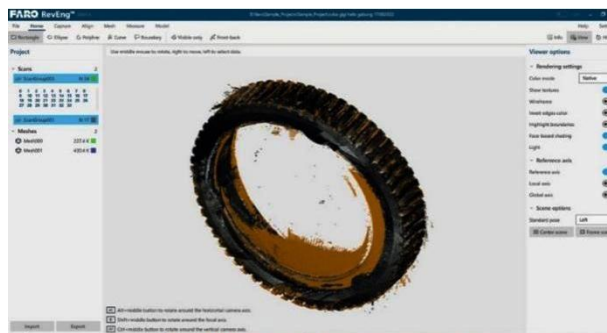

Fig. 6. 3D Scanning of brass worm gear ring.

3) Modified cloud worm gear ring

From the 3D scanning results into STL format, it is before modified into cloud data with CAD software, so that the original data for 3D printing is obtained, which is shown in Figure 7.

From the results of the processed STL, CAD software modifications were made to eliminate unused cloud data, resulting in Figure 8.

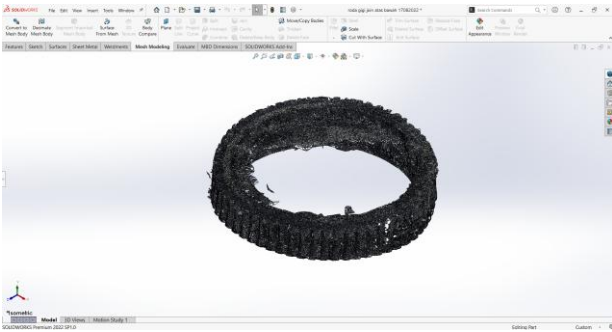

Fig. 7. Before modified cloud worm gear ring.

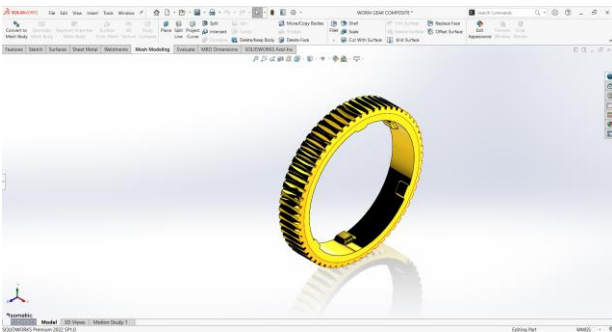

Fig. 8. Modified cloud worm gear ring.

The geometric design of refined cloud worm gear is obtained, as shown in the Figure 9 and Table 3.

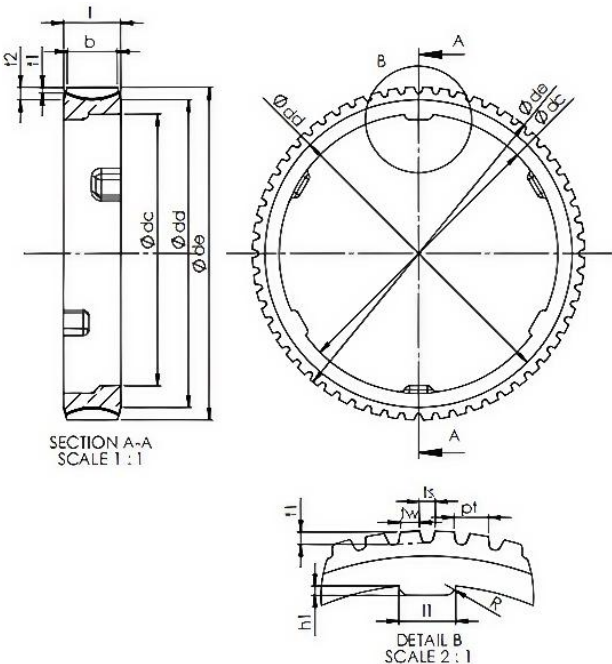

Fig. 9. Geometric design of worm gear rings.

Table 3. Geometric of worm gear ring.

Description	Worm Gear Ring
Materials	Onyx and Onyx + 10%CF
Module	1.5
Number of teeth (z)	60
Tooth thickness t1 (mm)	1.62
Tooth second thickness t2 (mm)	3.47
Tooth space ts (mm)	2.23

Description	Worm Gear Ring
Tooth width tw (mm)	2.5730
Pitch pt (mm)	4.69
Face width b (mm)	14
Face Gear l (mm)	16
Base Circle dc (mm)	78
Root Circle dd (mm)	86
Tip Circle de (mm)	93
Lock gear l1 (mm)	8
High lock gear h1 (mm)	1.29
Radius lock gear R (mm)	1.5
Center of distance (mm)	65
Normal pressure angle α (°)	20

4) 3D Printing Machine Setup

The Mark Two machine is a desktop version 3D printer for fabrication of commercial fiber-reinforced composites of Markforged with consideration of Onyx and Onyx+10%CF presented in Figure 10 [19].

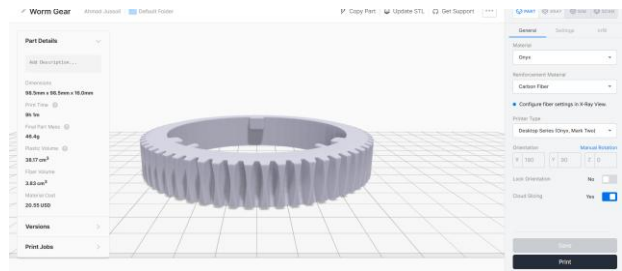

Fig. 10. Markforged 3D printing machine setup.

Calculating the volume of fiber carbon composite from Onyx obtained a value of around 10.5% [17]. Meanwhile, in the latest research, the fiber volume can be adjusted in software which is converted directly by 3D Printing at a value of 10%. The results of setting 10%CF in the Onyx composite can be obtained directly in the 3D Printer software are shown in Figure 10.

5) 3D Printing worm gear ring

After setting the machine parameters, the 3D printed composite worm gear rings is shown in Figure 11.

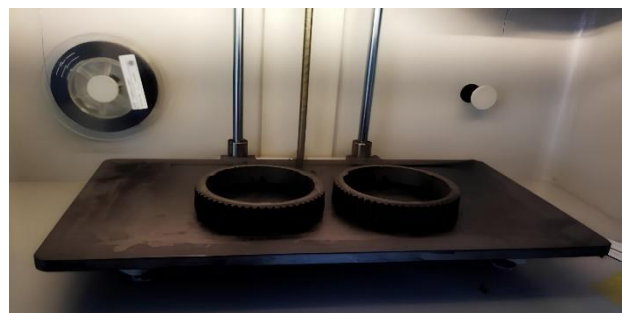

Fig. 11. 3D Printing process of composite worm gear ring.

2.3 Reduction gear loading

3D printed composite of a worm gear ring mounted on a stand is shown in Figure 12.



Fig. 12. Worm gear ring composite assembly.

Furthermore, torsional loading is carried out with ASTM E143-13 standard torsional test specimens of AISI 1020 low carbon steel, and the load measured by a spring scale is shown in Figure 13.



Fig. 13. Reduction gear loading in torque tests.

3. RESULT AND DISCUSSION

The loading of the composite worm gear ring obtained from the actual torque test calculation was intermittently assumed as a continuous load of 30 specimens with a minimum torque range of 22 Nm and a maximum of 26 Nm, and the total torsion duration between the composite worm gear ring and the medium carbon steel worm was obtained from the total torsion angle of 22800° with a rotation speed of 0.23 rpm in the torque test for a total continuous loading for 414 minutes or about nearly 7 hours. Torsion test specimens are made of low carbon steel with a rectangular size range of 5.93 mm x

160 mm. The 0.23 rpm rotation speed of the specimens was obtained from the calculation of 2-level deceleration through 2 reduction gears of a 1400 rpm electric motor with ratios of 1:100 and 1:60, respectively. The load value obtained from the average load read during the torque test.

F was 17 kg or 170 N. The value of the torsional moment is obtained because of multiplying the torsional force times the arm, $T=F.L$, on the machine used the arm, $L= 0.145$ m, so that $T = 170 \times 0.145 = 24.65$ Nm is obtained which is shown in Figure 14.

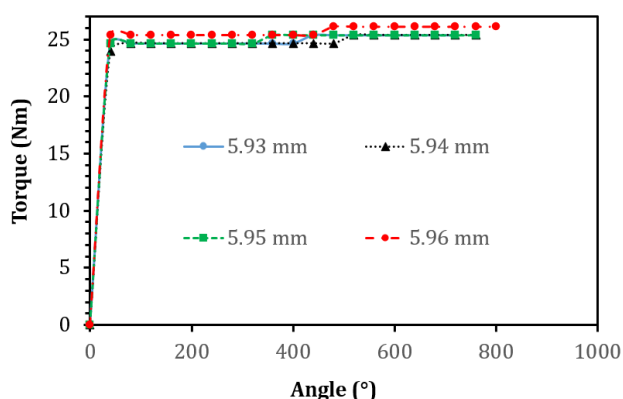

Fig. 14. One of the torque moments to test a specimens.

Meanwhile, to find out the location of the area, worm gear wear measurements were carried out in Figure 15, which was also carried out by previous researchers [5]. One example of measuring the wear of a composite worm gear ring with the help of SEM photographs after the wear of a friction sample in dry conditions was measured with the help of Autodesk Fusion 360 software is shown in Figure 16 and Figure 17, while Figure 18 is a comparison of the thickness of the 3D printed gear without testing.

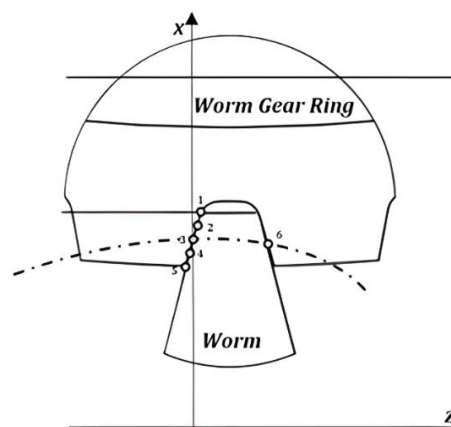

Fig. 15. The location of worm gear tooth thickness measurement using SEM photo is between point 3 and point 6.

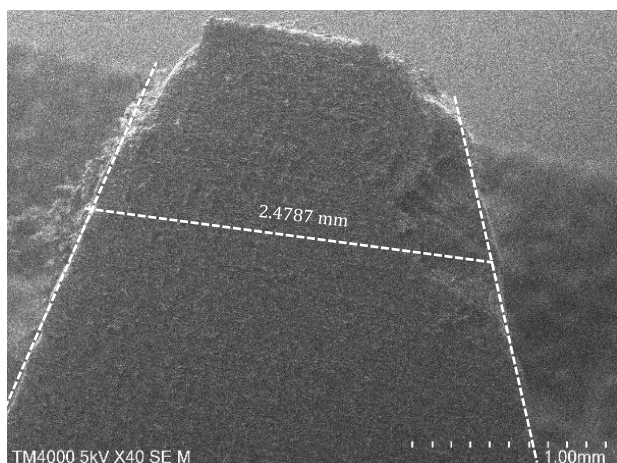

Fig. 16. The thickness of the Onyx material+10%CF tooth is 2.5100 mm.

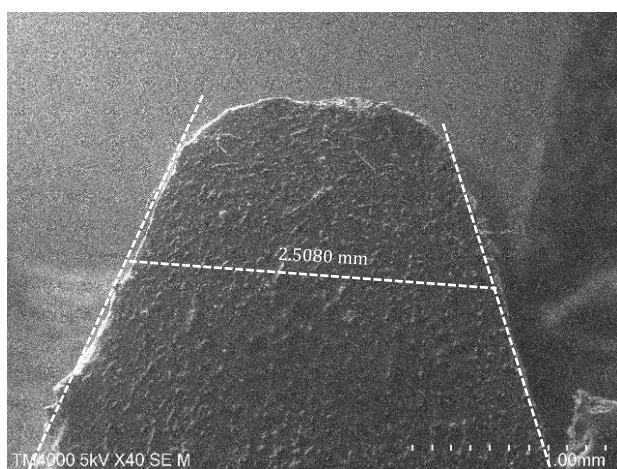

Fig. 17. The comparative tooth thickness without wear is 2.5730 mm.

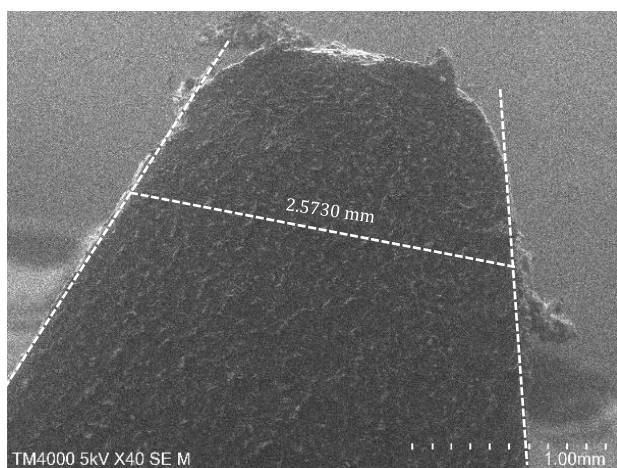

Fig. 18. The comparative tooth thickness without wear is 2.5730 mm.

The wear that occurs at the contact between the composite surface of the worm gear ring and the steel worm under dry lubrication conditions, using SAE 10W-30 oil and CLG shows different

values especially under dry conditions shown in Figure 16 is 2.4787 mm and Figure 17 is 2.5100 mm with the comparison of the 3D print alone in Figure 18 is 2.5730 mm.

The fiber shapes of the Onyx material are shown in Figure 19 and Figure 20, while the fiber of the carbon material is shown quite differently in Figure 20 where the Onyx fiber appear as tangled threads, and the CF are shown in a straight and elongated shape. The darker colour areas represent not fully filled layers of the result in 3D printing.

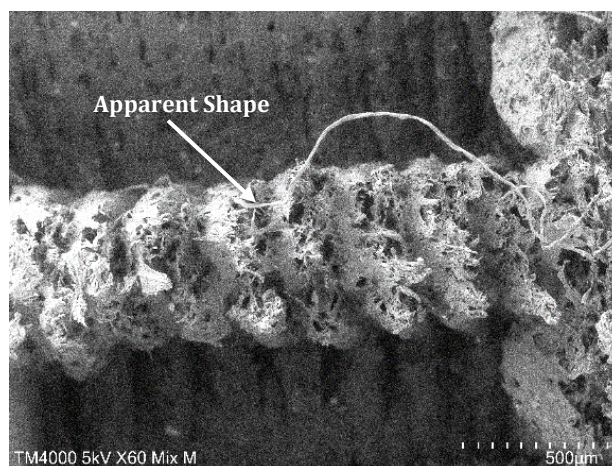

Fig. 19. Apparent Shape of Onyx Material Fiber.

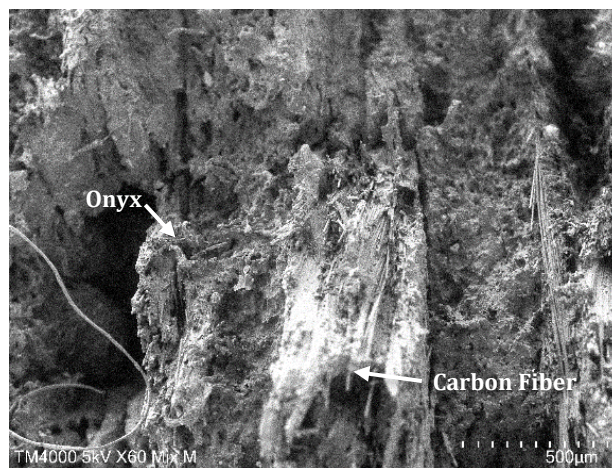

Fig. 20. One Form of Onyx Fiber Material Onyx+10%CF.

The various levels of wear on the tooth surfaces of the composite worm gear are shown in Table 4 represented in Figure 21.

Figure 21 shows the tooth wear level of 3 lubrication conditions, namely dry conditions, SAE 10W-30 oil, CLG, and 2 types of worm gear ring materials, namely Onyx and Onyx+10%CF. The highest wear level value is possessed by the

contact between the Onyx material worm gear ring composite and the medium carbon steel worm under SAE 10W-30 oil lubrication conditions which produces the largest wear of 0.0943 mm as measured from the SEM photograph at the tooth thickness after measurement of 2.4430 mm. The Onyx+10%CF worm gear ring composite material produces the largest wear of 0.0970 mm as measured from the SEM photograph at the tooth thickness after a measurement of 2.4760 mm.

Table 4. Tooth Thickness Worm Gear Rings.

Materials	Lubrication Conditions	Wear of Tooth (mm)	
		Tooth Thickness	Tooth Wear
Onyx	Dry	2.4787	0.0943
	Oil SAE 10W-30	2.4430	0.1300
	CLG	2.5080	0.0650
Onyx+10%CF	Dry	2.5100	0.0630
	Oil SAE 10W-30	2.4760	0.0970
	CLG	2.5700	0.0030
As comparison data		2.5730	0.0000

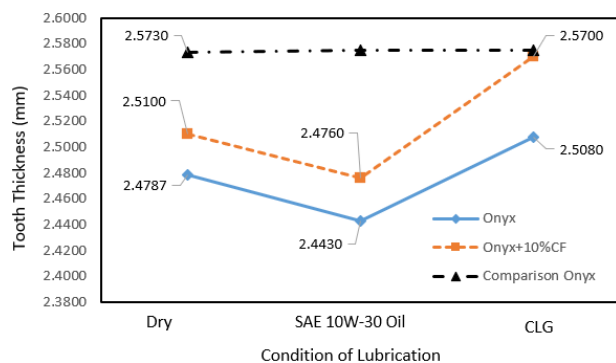

Fig. 21. Wear tooth composite worm gear rings.

The medium wear level is possessed by the contact between the composite worm gear ring made of Onyx material and the worm wheel made of medium carbon steel under dry lubrication conditions, which produces medium wear of 0.1300 mm as measured from the SEM photograph at the tooth thickness after measurement of 2.4787 mm, then for the worm gear ring Onyx+10%CF produces wear of 0.0630 mm as measured from the SEM photograph at the tooth thickness after measurement of 2.5100 mm.

The smallest wear level is possessed by the contact between the composite worm gear ring of Onyx material and the worm of medium carbon steel material under CLG lubrication conditions which produces of 0.0650 mm as measured from the SEM photograph at the tooth thickness after

measurement of 2.5080 mm and then for the worm gear ring of Onyx+10%CF material produces of 0.0030 mm as measured from the SEM photograph at the tooth thickness after measurement of 2.5700 mm. In the condition of three different lubrications for worm gear ring with Onyx material compared to the condition without testing has a thickness of 2.5730 mm consecutively from the highest to lowest values are achieved by lubrication conditions with SAE 10W-30 oil of 5.05%, dry lubrication of 3.66%, and CLG of 2.53%, while the worm gear ring with Onyx+10%CF successively shows from the highest to the lowest values achieved in lubrication conditions with SAE 10W-30 oil of 3.77%, dry lubrication of 2.45%, and CLG of 0.12%.

The friction between the worm and the worm gear ring for dry conditions is at a coefficient of friction value $\mu = 0.1 \div 0.3$, which can cause some of the remaining carbon fiber composite to stick to the friction surface of the carbon steel worm, which is detected from EDS identification at certain points from the SEM photograph as a sign trace of wear. It was identified that composites in the dry condition could be considered adhesive wear, previous research also found that the low friction properties found in carbon fiber reinforced composites were similar. Carbon fiber makes a significant contribution to reducing the effect of friction with the contact area between the metal surface and the composite surface [20], while the interaction conditions between tooth contacts are assumed to be constant until wear occurs, a lower friction coefficient can reduce composite deformation.

The use of SAE 10W-30 oil on the contact between Onyx+10%CF on medium carbon steel worms experienced increased wear which indicated a darkening of the colour of the remaining oil. The metal-polymer composite friction coefficient under oil lubrication conditions with carbon fiber added in 3D printing is assumed to be close to the value in the range $\mu = 0.05 \div 0.6$, which is possessed by the friction coefficient between metal-polymer train gear pairs, which also have carbon fiber added [21]. Both are considered to have the same wear condition.

The condition of the measurement results for the thickness of the Onyx+10%CF worm gear ring shows that the smallest wear occurs under grease

(CLG) lubrication conditions, while the friction coefficient using grease is in the range $\mu = 0.04 \div 0.08$, which is caused by the weak adhesion effect due to the coating on the contact, which directly reduces friction between metal-polymer composite [22], so that the wear that occurs between the worm gear ring and the steel worm is reduced due to the film layer formed. The findings of experimental wear studies show an almost linear relationship between test duration, wear level, and torque increase this was also found in the last research where the wear was linear.

4. CONCLUSIONS AND SUGESTION

From the results of the discussion, it can be concluded that the wear from the largest value to the smallest value is successively owned by: (1) friction conditions between the tooth of Onyx materials and medium carbon steel worm in the reduction gear soaked in SAE 10W-30 oil, dry condition, and Castrol Lithium grease (CLG); (2) friction conditions between the tooth of Onyx material and medium carbon steel worm in the reduction gear from the largest value to the from smallest value are owned by SAE 10W-30 oil (0.1300 mm), dry (0.0943 mm), and CLG (0.0650 mm); (3) the friction between the tooth of Onyx+10%CF (10% Carbon Fiber) on medium carbon steel worm in the reduction gear from the largest value to the smallest value belongs to SAE 10W-30 oil (0.0970 mm), dry (0.0630 mm), and CLG (0.0030 mm); and (4) there is an unfavourable interaction between SAE 10W-30 oil and Onyx composite material which indicates the solubility of the substance, resulting in a darker colour.

A follow-up suggestion to these conclusions is to conduct research that avoids the use of lubrication that can react with the composite material of the worm gear ring resulting in more serious wear.

Acknowledgement

The authors would like to express their gratitude for the research funding support and the Reverse Engineering Laboratory facilities, Master of Applied Manufacturing Engineering Study Program, Department of Mechanical Engineering, State Polytechnic of Malang, Indonesia.

REFERENCES

- [1] R. Honkalas, B. Deshmukh, and P. Pawar, "A review on design and efficiency improvement of worm and worm wheel of a gear motor," *Journal of Physics Conference Series*, vol. 1969, no. 1, p. 012023, Jul. 2021, doi: [10.1088/1742-6596/1969/1/012023](https://doi.org/10.1088/1742-6596/1969/1/012023).
- [2] A. Miltenović, M. Banić, and Đ. Miltenović, "Load capacity of cylindrical worm gears according to DIN 3996-2012," *Machine Design*, vol. 9, no. 2, pp. 45-50, Jun. 2017, doi: [10.24867/md.9.2017.2.45-50](https://doi.org/10.24867/md.9.2017.2.45-50).
- [3] S. Raadnui, "Condition monitoring of worm gear wear and wear particle analysis of industrial worm gear sets," *Wear*, vol. 476, p. 203687, Feb. 2021, doi: [10.1016/j.wear.2021.203687](https://doi.org/10.1016/j.wear.2021.203687).
- [4] Z. Shi, J. Ren, Z. Feng, and J. Li, "Key technology and experimental study of unequal pitches meshing between metal worm and plastic helical gears," *Applied Sciences*, vol. 11, no. 1, p. 333, Dec. 2020, doi: [10.3390/app11010333](https://doi.org/10.3390/app11010333).
- [5] M. Czerniec and A. Świć, "Study of contact strength, tooth wear and metal-polymer life of worm gears," *Advances in Science and Technology - Research Journal*, vol. 16, no. 3, pp. 143-154, Jun. 2022, doi: [10.12913/22998624/149608](https://doi.org/10.12913/22998624/149608).
- [6] M. Chernets, "Research of influence of engagement pairing of the corrected worm gear with involute worm on the life and contact pressure," *Tribology in Industry*, vol. 42, no. 3, pp. 363-369, Sep. 2020, doi: [10.24874/ti.846.02.20.05](https://doi.org/10.24874/ti.846.02.20.05).
- [7] M. V. Chernets, "Prediction method of contact pressures, wear and life of worm gears with archimedean and involute worm, taking tooth correction into account," *Journal of Friction and Wear*, vol. 40, no. 4, pp. 342-348, Jul. 2019, doi: [10.3103/s1068366619040032](https://doi.org/10.3103/s1068366619040032).
- [8] H. K. Trivedi and D. V. Bhatt, "Effect of lubricating oil on tribological behaviour in pin on disc test rig," *Tribology in Industry*, vol. 39, no. 1, pp. 90-99, Mar. 2017, doi: [10.24874/ti.2017.39.01.10](https://doi.org/10.24874/ti.2017.39.01.10).
- [9] M. Chernets, "A method for predicting contact strength and life of archimedes and involute worm gears, considering the effect of wear and teeth correction," *Tribology in Industry*, vol. 41, no. 1, pp. 134-141, Mar. 2019, doi: [10.24874/ti.2019.41.01.15](https://doi.org/10.24874/ti.2019.41.01.15).
- [10] S. M. Lee, M. W. Shin, and H. Jang, "Effect of carbon-nanotube length on friction and wear of polyamide 6,6 nanocomposites," *Wear*, vol. 320, pp. 103-110, Aug. 2014, doi: [10.1016/j.wear.2014.08.011](https://doi.org/10.1016/j.wear.2014.08.011).

- [11] P. Melnikov and S. Schegoleva, "Methods of increasing the efficiency of the worm gear," *MATEC Web of Conferences*, vol. 298, p. 00001, Jan. 2019, doi: [10.1051/mateconf/201929800001](https://doi.org/10.1051/mateconf/201929800001).
- [12] S. Kopčanová, M. Kučera, M. Kučera, M. Kučera, and V. . Kučerová, "The effect of friction behaviour and wear protection ability of selected base lubricants on tribo-pairs parameters of machine components," *Tribology in Industry*, vol. 40, no. 4, pp. 681–691, Dec. 2018, doi: [10.24874/ti.2018.40.04.14](https://doi.org/10.24874/ti.2018.40.04.14).
- [13] R. Kozdrach, "The innovative research methodology of tribological and rheological properties of lubricating grease," *Tribology in Industry*, vol. 43, no. 1, pp. 117–130, Mar. 2021, doi: [10.24874/ti.941.08.20.11](https://doi.org/10.24874/ti.941.08.20.11).
- [14] A. Shalwan, S. Mallampati, and B. F. Yousif, "Abrasive wear performance of coir fiber reinforced polymer composite," *Tribology in Industry*, vol. 45, no. 3, pp. 532–541, Sep. 2023, doi: [10.24874/ti.1500.06.23.07](https://doi.org/10.24874/ti.1500.06.23.07).
- [15] J. M. Chacón, M. A. Caminero, P. J. Núñez, E. García-Plaza, I. García-Moreno, and J. M. Reverte, "Additive manufacturing of continuous fibre reinforced thermoplastic composites using fused deposition modelling: effect of process parameters on mechanical properties," *Composites Science and Technology*, vol. 181, p. 107688, Jun. 2019, doi: [10.1016/j.compscitech.2019.107688](https://doi.org/10.1016/j.compscitech.2019.107688).
- [16] M. Chernets and A. Kornienko, "Prediction of the service life of metal-polymer gears made of glass and carbon fibre-reinforced polyamide, considering the impact of height correction," *Advances in Science and Technology - Research Journal*, vol. 14, no. 3, pp. 15–21, Aug. 2020, doi: [10.12913/22998624/124553](https://doi.org/10.12913/22998624/124553).
- [17] A. N. Dickson, J. N. Barry, K. A. McDonnell, and D. P. Dowling, "Fabrication of continuous carbon, glass and kevlar fibre reinforced polymer composites using additive manufacturing," *Additive Manufacturing*, vol. 16, pp. 146–152, Jun. 2017, doi: [10.1016/j.addma.2017.06.004](https://doi.org/10.1016/j.addma.2017.06.004).
- [18] S. M. F. Kabir, K. Mathur, and A.-F. M. Seyam, "The road to improved fiber-reinforced 3d printing technology," *Technologies*, vol. 8, no. 4, p. 51, Sep. 2020, doi: [10.3390/technologies8040051](https://doi.org/10.3390/technologies8040051).
- [19] "Markforged, material specifications," Markforged. <https://markforged.com/materials>. (accessed Nov. 12, 2024).
- [20] T. Kunishima, Y. Nagai, G. Bouvard, J.-C. Abry, V. Fridrici, and P. Kapsa, "Comparison of the tribological properties of carbon/glass fiber reinforced PA66-based composites in contact with steel, with and without grease lubrication," *Wear*, vol. 477, p. 203899, Apr. 2021, doi: [10.1016/j.wear.2021.203899](https://doi.org/10.1016/j.wear.2021.203899).
- [21] M. Chernets, A. Kornienko, Yu. Chernets, and S. Fedorchuk, "Analytical assessment of the sliding friction coefficient influence on durability, wear and contact pressure in spur gears," *FME Transaction*, vol. 49, no. 2, pp. 472–479, Jan. 2021, doi: [10.5937/fme2102472c](https://doi.org/10.5937/fme2102472c).
- [22] Z. Bergant, R. Šturm, D. Zorko, and B. Černe, "Fatigue and wear performance of autoclave-processed and vacuum-infused carbon fibre reinforced polymer gears," *Polymers*, vol. 15, no. 7, p. 1767, Apr. 2023, doi: [10.3390/polym15071767](https://doi.org/10.3390/polym15071767).